

---

Reference Manual

# ***SERIES* 8000**

# **ENCLOSURES**

Copyright © 2000  
PART NO: 860093-001  
Last Revised: 3/16/01

**KAMAN**

Kaman Aerospace Corporation  
Measuring & Memory Systems  
217 Smith Street  
Middletown, CT 06457

[www.kamansensors.com](http://www.kamansensors.com) or 860-632-4442



# ***Series 8000 Enclosures***

## **Reference Manual**

1/2 Rack Instrumentation Case (3U/42HP)

3/4 Rack Instrumentation Case (3U/63HP)

Full 19" Subrack (3U/84HP)

## **Series 8000 Systems**

The *Series 8000* is a modular packaging system for Kaman Instrumentations line of inductive displacement transducer electronics. The *Series 8000* enclosures integrate various measuring channels, function cards, power supplies, and displays into a coherent application specific industrial package. Sensors for the measuring channels are available that measure displacements in the microinch/nanometer ranges as well as sensors that can make accurate displacement measurements at up to 1000°F. Function cards are available that can take the displacement measurement and process the signal to measure ID, OD,runout, or out of tolerance conditions. The versatility and flexibility of the 8000 system is virtually endless. This manual is designed to help put it all together for the specific system you have purchased.

features:

- Eurocard/Eurorack format
- Up to 12 channel systems
- Integral rear mounted power supplies
- Terminal block I/O
- Optional 1/8 DIN display modules
- Multi-channel Scalable displays
- Inductive sensing technology
- Plug-in function modules for:
  - Dynamic signal measurement
  - Set point window comparators
  - Summation for thickness/ID/OD measurement
  - 4-20 mA outputs

<b>Table of Contents</b>	<b>Page</b>
Getting Started Quickly	7
Series 8000 Enclosures	8
Subracks	8
Instrument Enclosure	13
NEMA	17
Integral Power Supply	18
Input Voltage Selection (120VAC/240VAC)	19
The Internal Back Plane	23
Internal Back Plane Connectors	25
Adding Additional Modules	26
The Back Panel	29
Back Panel Power Input	29
Back Panel I/O and Labeling	30
Back Panel Sensor Inputs	31
The Front Panels	32
Module Side Panel Labeling	32
MCD-8000 and 1/8 DIN Panel Mounted Displays	33
Using the Multi-Inputs	35
Input wiring to the Display	36
0-10VDC Display Input Configuration	37
+/-5VDC Display Input Configuration	37
+/-10VDC Display Input Configuration	37
4-20mA Display Input Configuration	38
Calibration	39
Appendix A -- Measuring Channel Configuration	43
Basic Measuring Channel Configuration	44
Appendix B -- Function Card Configuration	45
VC8000 Voltage to Current Converter Configuration	46
SC8000 Summation/Comparator Configuration	47
DY8000 Dynamic Module Configuration	48
SP8000 Dual Set Point Configuration	49
Appendix C -- MCD-8000 Display Specifications	50
MCD 8000 Functional Specifications	50
MCD 8000 Performance Specifications	51
MCD 8000 Environmental/Physical Specifications	51
Appendix D -- Replacement or Expansion Parts	52
Appendix E -- Warranty, Customer Service and Service/Repair	54

**List of Illustrations****Page**

fig. 1 -- Full 19" Subrack Rear/Front Outline drawing	9
fig. 2 -- Full 19" Subrack Top View Outline Drawing	10
fig. 3 -- Full 19" Subrack Rear/Front with Display	11
fig. 4 -- Full 19" Subrack Rear/Front with Dual Display	12
fig. 5 -- 1/2 Rack with Display Outline Drawing	14
fig. 6 -- 1/2 Rack Outline Drawing	15
fig. 7 -- 3/4 Rack with Display Outline Drawing	16
Table 1 -- Power Supply Specifications	18
fig. 8 -- Power Entry Module	19
fig. 9 -- Accessing the Voltage Selector Card	19
fig. 10 -- Voltage Selector Card Orientation	20
fig. 11 -- Top View of Main board on display.	22
fig. 12 -- Physical Eurocard Pin Locations	23
Table 2 -- Electrical Standards for Pinout	24
fig. 13 -- Single Coil Coaxial	25
fig. 14 -- Dual Coil Coaxial	25
fig. 15 -- Back Plane Template	28
fig. 16 -- Power Entry Module	29
Table 3 -- Terminal Block Labeling	30
fig. 17 -- Back Panel Sensor Inputs	31
fig. 18 -- Typical Module Side Panel Labeling	32
fig. 19 -- Single 1/8 DIN Mounting Panel 814873-001	33
fig. 20 -- Dual 1/8 DIN Mounting Panel 814873-002	34
fig. 21 -- MCD 8000 Front Panel	35
Table 4 -- Displayed Outputs	35
fig. 22 -- MCD 8000 Input Wiring	36
fig. 23 -- MCD 8000 Power Wiring	36
fig. 24 -- Voltage/Current Input Dip Switch	38
fig. 25 -- Diodes For Loop Continuity in Current Mode	38
fig. 26 -- MCD 8000 Adjustment Switches	40
fig. 27 -- Process/Scaling Dip Switch	40
fig. 28 -- Button Function Legend	42
Table 5 -- MCD-8000 Error Message Table	42
Table 6 -- Series 8000 Sensor Family	43
fig. 29 -- Basic Measuring Channel	44
fig. 30 -- Module Reference Dimensions	45
fig. 31 -- VC8000 Voltage to Current Converter	46
fig. 32 -- SC8000 Summation/Comparator	47
fig. 33 -- DY8000 Dynamic Module	48
fig. 34 -- SP8000 Dual Set Point	49

## Getting Started Quickly

The *Series 8000* rack systems are typically prewired and set up at the factory with all measuring channels and function cards installed. To get started with the 8000 system you will need to:

- a** Install the sensors in the application or cal fixture
- b** Connect the sensors to the enclosure (see page 30)
- c** Connect the power cord and turn on the unit
- d** If you have a display see page 32
- e** If you have no display see page 29 on back panel I/O

As with any complex electronics system you should thoroughly familiarize yourself with all manuals dealing with the product. Included with the system are the appropriate manuals for any measuring channels and function cards purchased. Please refer to these manuals for specific information.

<p><b>Warning:</b> The integral power supply in racks utilize <b>high voltage</b> (120 or 240VAC). Unplug the unit before servicing.</p>
--

## **Series 8000 Enclosures**

### **Subracks**

The subrack is a 19" wide frame having solid side panels and horizontal rails across the top and bottom to hold the system modules in place. Use of a subrack enables you to install your Series 8000 system into a standard 19" test equipment rack, or bolt it into a NEMA enclosure. The subrack has a built in 120VAC/240VAC selectable power supply to provide +/-15VDC at 1 amp. The subrack also can be configured with either one or two MCD 8000 display modules that have up to six selectable inputs. The display modules draw no current from the +/-15 volt supply.

#### Full 19" Sub-Racks - 3U/84HP Instrumentation Subrack

Part Number	Configuration
853705-000	No display meter, 12 available positions
853705-001	One display meter, 9 available positions
853705-002	Two display meters, 9 available positions



REV.	DATE	DESCRIPTION
X		PRELIM. ISSUE
A		INITIAL RELEASE PER ECO

TOP

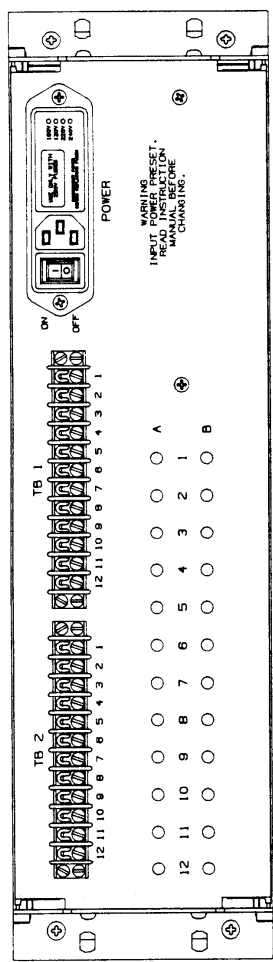

REAR VIEW

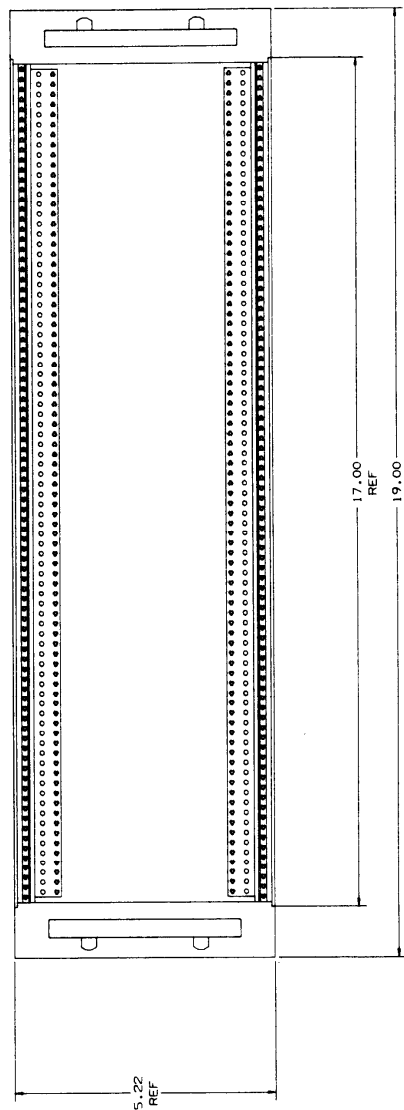

- NOTES:
1. REF K1 ASSEMBLY P/N 853705-000.
  2. TWELVE AVAILABLE MEASURING CHANNEL/ FUNCTION MODULE POSITIONS.

REV.	DATE	DESCRIPTION
D	7/10/28	801085

DO NOT SCALE THIS DRAWING	DATE	SCALE	PROJECT
UNLESS OTHERWISE SPECIFIED:	DATE	SCALE	PROJECT
TOLERANCES:	DATE	SCALE	PROJECT
FRACTIONS:	DATE	SCALE	PROJECT
DECIMALS:	DATE	SCALE	PROJECT
ANGLES:	DATE	SCALE	PROJECT
SURFACE FINISHES:	DATE	SCALE	PROJECT
MATERIAL:	DATE	SCALE	PROJECT

KAMAN	
OUTLINE 8000 SERIES MEASUREMENT SYSTEM, 19" SUBRACK	
REV.	A
DATE	7/10/28
DRG. NO.	801085
SCALE	1:1
SHEET	1 OF 2

fig.1 - Full 19" Subrack Rear/Front Outline Drawing

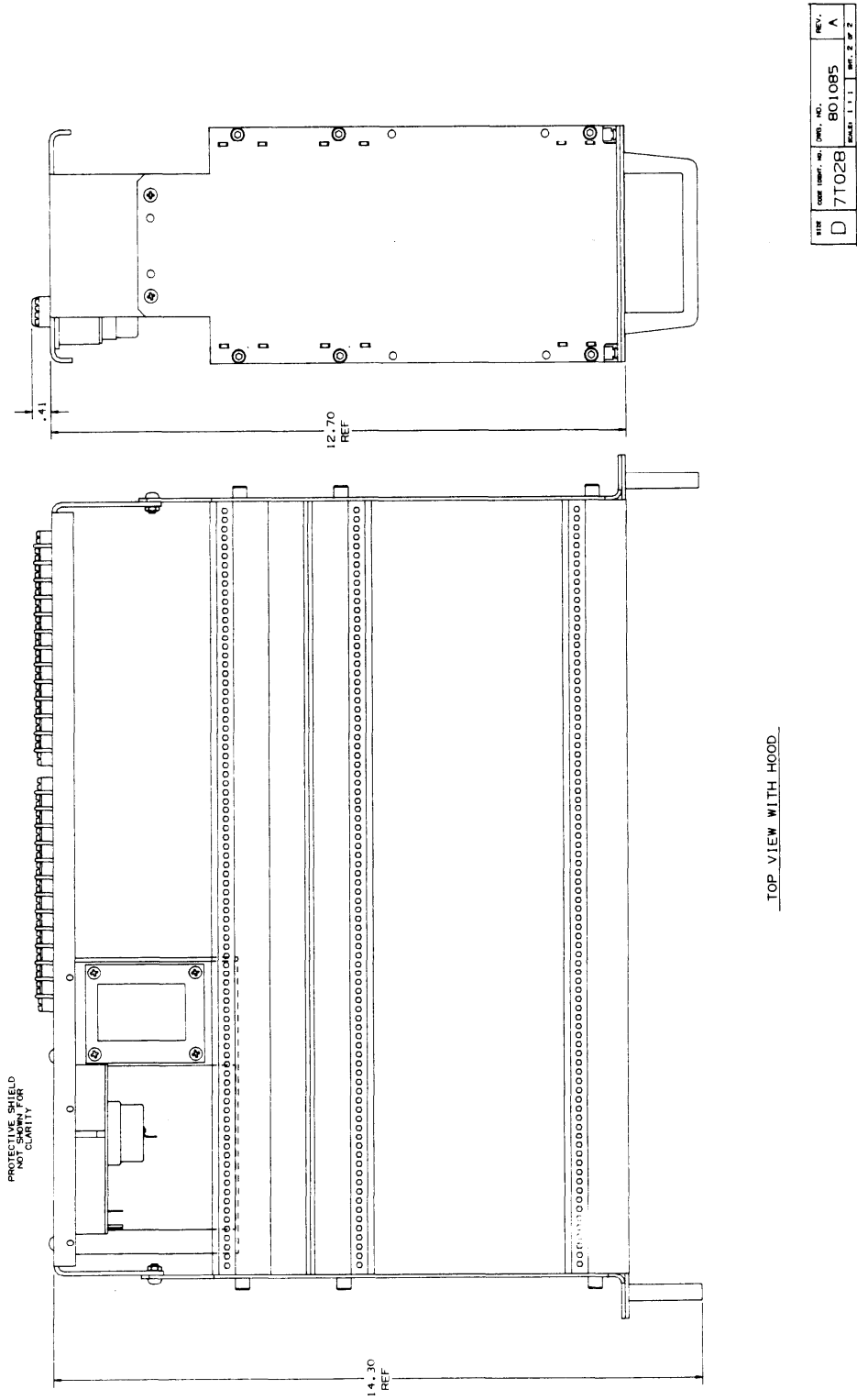
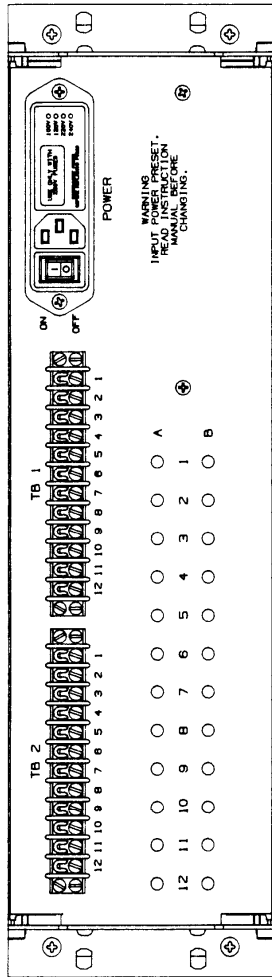

Fig. 2 - Full 19" Subrack Top View Outline Drawing



REV.	DATE	APPROVED
1		
2		
3		
4		
5		
6		
7		
8		
9		
10		
11		
12		
13		
14		
15		
16		
17		
18		
19		
20		
21		
22		
23		
24		
25		
26		
27		
28		
29		
30		
31		
32		
33		
34		
35		
36		
37		
38		
39		
40		
41		
42		
43		
44		
45		
46		
47		
48		
49		
50		
51		
52		
53		
54		
55		
56		
57		
58		
59		
60		
61		
62		
63		
64		
65		
66		
67		
68		
69		
70		
71		
72		
73		
74		
75		
76		
77		
78		
79		
80		
81		
82		
83		
84		
85		
86		
87		
88		
89		
90		
91		
92		
93		
94		
95		
96		
97		
98		
99		
100		

TOP



REAR VIEW

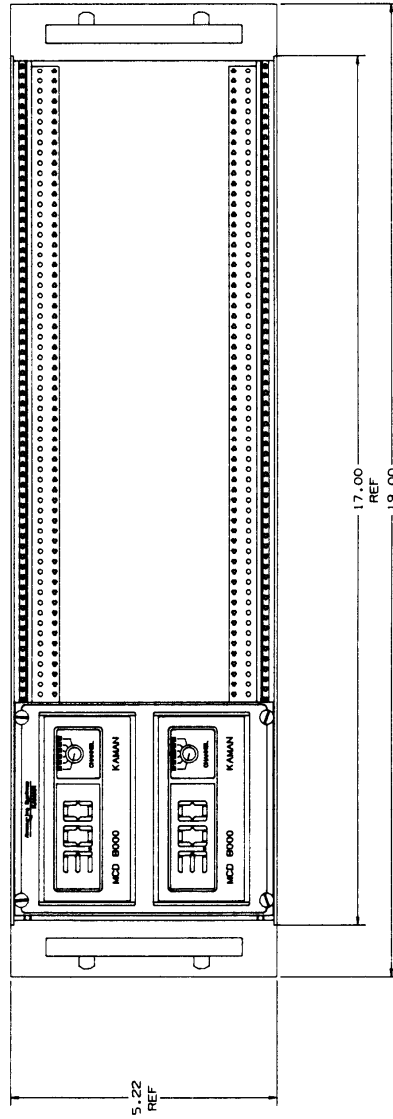

NOTES:

1. REF K1 ASSEMBLY P/N 853705-002.
2. NINE AVAILABLE MEASURING CHANNEL/FUNCTION MODULE POSITIONS.

REV.	DATE	APP.	BY
1			
2			
3			
4			
5			
6			
7			
8			
9			
10			
11			
12			
13			
14			
15			
16			
17			
18			
19			
20			
21			
22			
23			
24			
25			
26			
27			
28			
29			
30			
31			
32			
33			
34			
35			
36			
37			
38			
39			
40			
41			
42			
43			
44			
45			
46			
47			
48			
49			
50			
51			
52			
53			
54			
55			
56			
57			
58			
59			
60			
61			
62			
63			
64			
65			
66			
67			
68			
69			
70			
71			
72			
73			
74			
75			
76			
77			
78			
79			
80			
81			
82			
83			
84			
85			
86			
87			
88			
89			
90			
91			
92			
93			
94			
95			
96			
97			
98			
99			
100			

fig. 4 - Full 19" Subrack Rear/Front with Dual Display

## **Instrument Enclosure**

The instrument case is a fully enclosed stand-alone enclosure for your series 8000 system with a tilt bar to elevate the front of the case. The subrack has a built in 120VAC/240VAC selectable power supply to provide +/-15VDC at 500 milliamp. The subrack also can be configured with either one or two MCD 8000 display modules that have up to six selectable inputs. The display modules draw no current from the +/-15DC volt supply.

### 1/2 rack enclosures - 3U/42HP Instrumentation enclosure

Part Number Configuration

853704-000 No display meter, 6 available positions

853704-001 One display meter, 3 available positions

### 3/4 rack enclosures - 3U/63HP Instrumentation enclosure

Part Number Configuration

853723-001 One display meter, 6 available positions

REVISIONS		
REV.	DESCRIPTION	DATE
X	PRELIM. ISSUE	
A	INITIAL RELEASE PER ECOP	

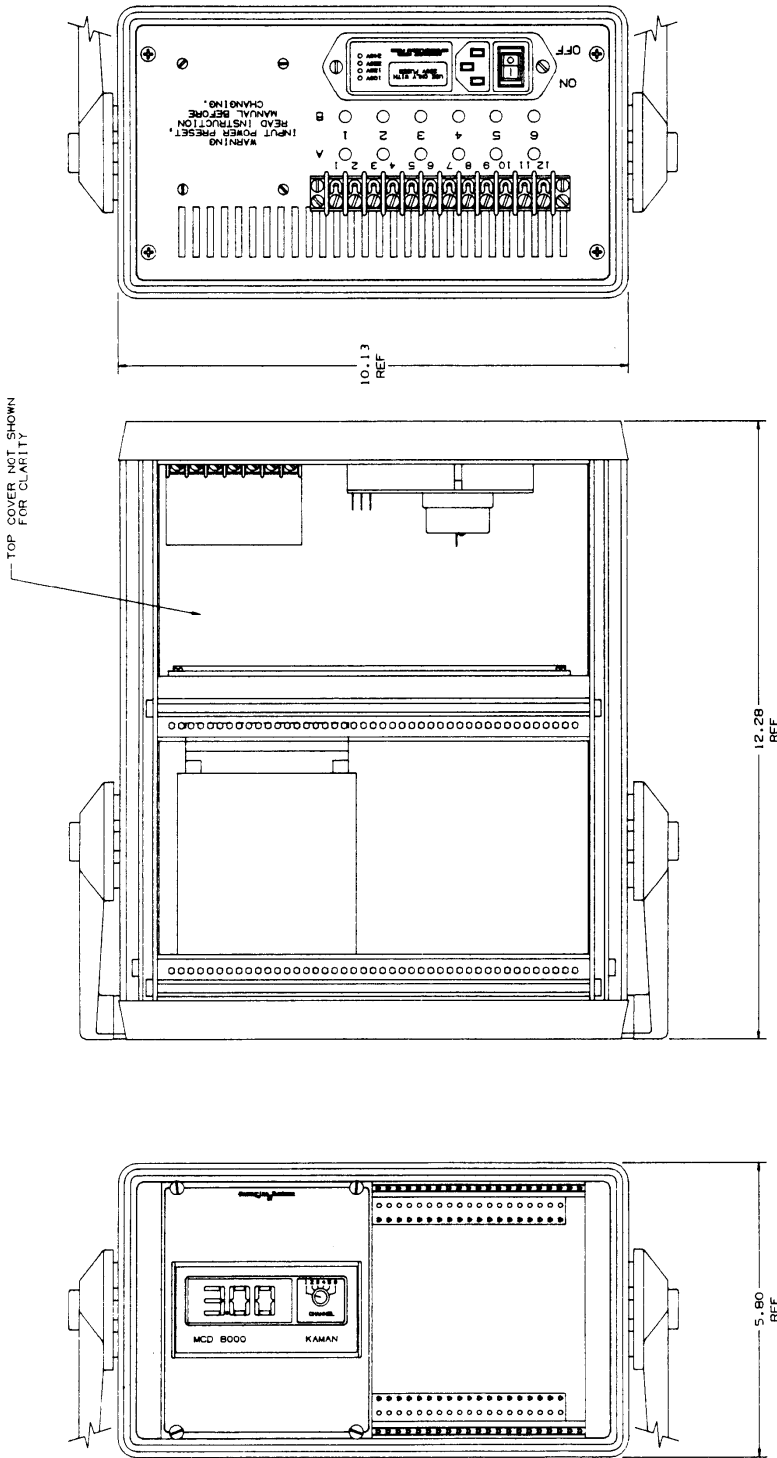

KAMAN	
OUTLINE, 8000 SERIES MEASUREMENT SYSTEM, SINGLE DISPLAY, 1/2 RACK ENCLOSURE	
FILE	801081
REV.	A
DATE	7/10/68
ISSUED BY	
APPROVED BY	
APPLICATION	
DO NOT SCALE THIS DRAWING UNLESS SPECIFICALLY NOTED OTHERWISE	
ALL DIMENSIONS UNLESS OTHERWISE SPECIFIED	
DIMENSIONS ARE IN INCHES	
TOLERANCES	
FINISH	
ANGLE ± 1°	
SURFACE FINISHES	
VERTICAL	

- NOTES:
1. REF K1 ASSEMBLY P/N 853704-001.
  2. THREE AVAILABLE MEASURING CHANNEL/FUNCTION MODULE POSITIONS.

fig.5 - 1/2 Rack with Display Outline Drawing



REV.	DATE	APPROVED	REVISIONS
X			PRELIM. ISSUE
A			INITIAL RELEASE PER EGCP

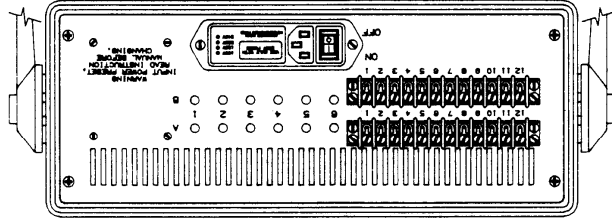

TOP COVER NOT SHOWN FOR CLARITY

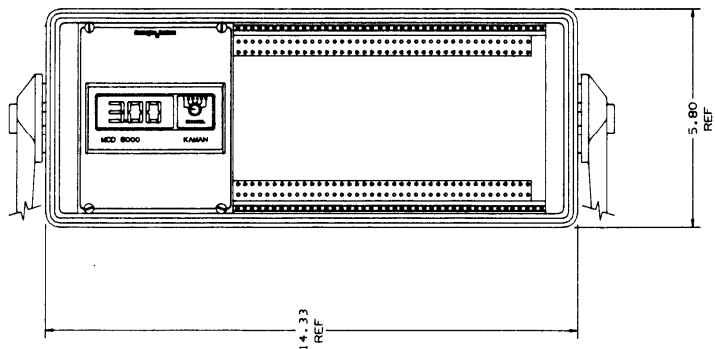
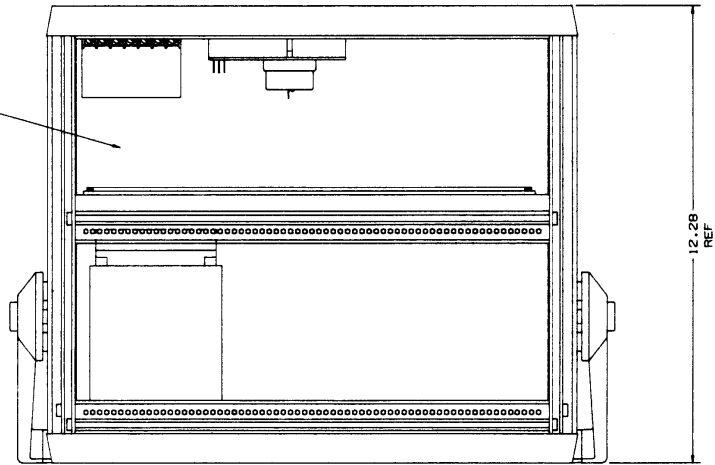

DO NOT SCALE THIS DRAWING UNLESS OTHERWISE SPECIFIED; DIMENSIONS ARE IN INCHES TOLERANCES: .005 ± 0.000 .010 ± 0.010 SURFACE FINISHES: ✓ MAX MATERIAL		KAMAN OUTLINE DRAWING MEASUREMENTS TABLE DISPLAY, 3/4 RACK ENCLOSURE
DATE	7/02/86	REV. A
DESIGNER		
CHECKED		
APPROVED		
PROJECT		
DRAWN		
SCALE	1:1	REV. 1 OF 1

- NOTES:
- REF K1 ASSEMBLY P/N 853723-001.
  - SIX AVAILABLE MEASURING CHANNEL/FUNCTION MODULE POSITIONS.

fig. 7 - 3/4 Rack with Display Outline Drawing



## **NEMA**

The NEMA 12 configuration is an 8"x8"x4" continuous hinge enclosure. It can contain either 1 or 2 synchronized measuring channels and an optional function card. An optional integral power supply and/or display is available. In the NEMA the modules do not have separate enclosures. *This configuration is not described further in this manual, please refer to the NEMA manual PN 860060 for further information on the NEMA enclosure.*

<u>PN</u>	<u>Configuration</u>
853638-001	Standard NEMA
853639-001	NEMA with internal 120VAC power supply
853640-001	NEMA with display
853641-001	NEMA with 120VAC PS and display
853639-001E	NEMA with 240 VAC power supply
853641-001E	NEMA with 240 VAC power supply and display



## Input Voltage Selection (120VAC/240VAC)

**Warning:** When you change the input voltage on the rear panel you must also change the MCD 8000 input voltage or you may damage the unit.

**Warning:** The integral power supply in racks utilize **high voltage** (120 or 240VAC). Unplug the unit before servicing.

To change the input voltage you must first select the proper input voltage on the power entry module on the unit. To change the selected voltage:

- a Open the cover using a small blade screwdriver or similar tool. Set aside the cover/fuse block assembly and pull the voltage selector card straight out of the housing. See fig. 9 on accessing the voltage selector card.

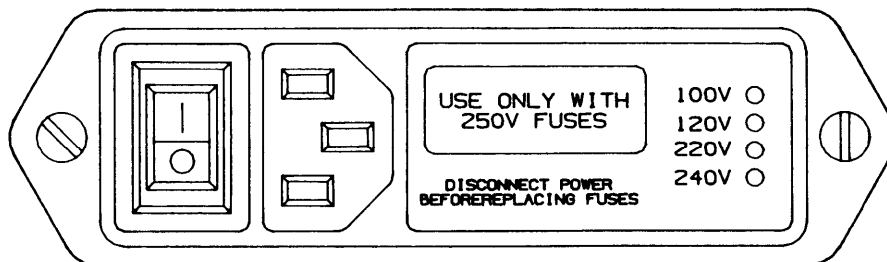

fig. 8 -- Power Entry Module;

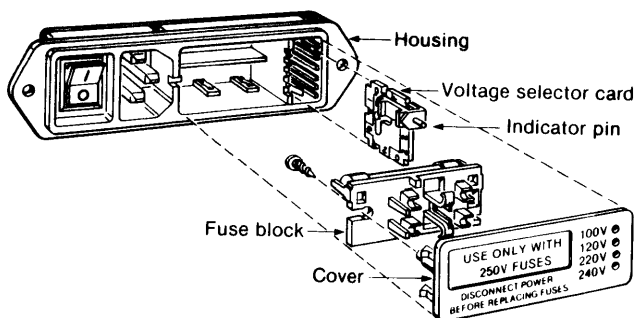
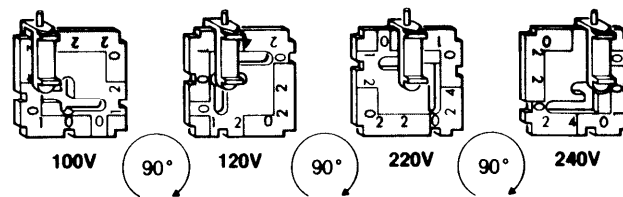

fig. 9 -- Accessing the Voltage Selector Card;

- b** Using the indicator pin orient the selector card so that the desired voltage is readable at the bottom. Orient the indicator pin to point up when the desired voltage is readable at bottom ( note that when indicator pin is fixed, successive voltages are selected by rotating the card  $90^{\circ}$  clockwise). See fig. 10 for voltage selector orientation.
- c** Insert voltage selector card into housing with printed side of card facing toward IEC connector and edge containing the desired voltage first. Replace cover and verify that indicator pin shows the desired voltage.



**fig. 10 -- Voltage Selector Card Orientation;**

If you have an MCD 8000 (for other 1/8 DIN panel meter configurations you will need to see the specific manual on the meter for changing the input voltage) 110VAC or 220VAC is selectable using a switch on the indicators main circuit board. Check the instruments tag for the voltage range set at the factory. *If you are changing the input voltage to the unit you will need to set this switch appropriately.* To change the input voltage on the MCD 8000 display module perform the following steps:

**Warning:** When you change the input voltage on the rear panel you must also change the MCD 8000 input voltage or you may damage the unit.

**Warning:** The integral power supply in racks utilize **high voltage** (120 or 240VAC). Unplug the unit before servicing.

- a** Remove the MCD-8000 unscrew the 4 screws holding the unit in the chassis. You will need to very carefully pull this out of the enclosure to get at the voltage selector switch. Be careful not to pull out any of the wires attached to the terminal block of the MCD 8000.
- b** Remove the input selector knob and face plate and spread the black box to remove the PC board. There is a plastic tab on the bottom side that holds the PC board in place. Spreading the box slightly will allow the PC board to slip over the top.
- c** On the main display board set the voltage switch for the appropriate input voltage and replace the unit. See fig. 11 for a top view of the main display board.
- d** Reinstall the display module in the unit.

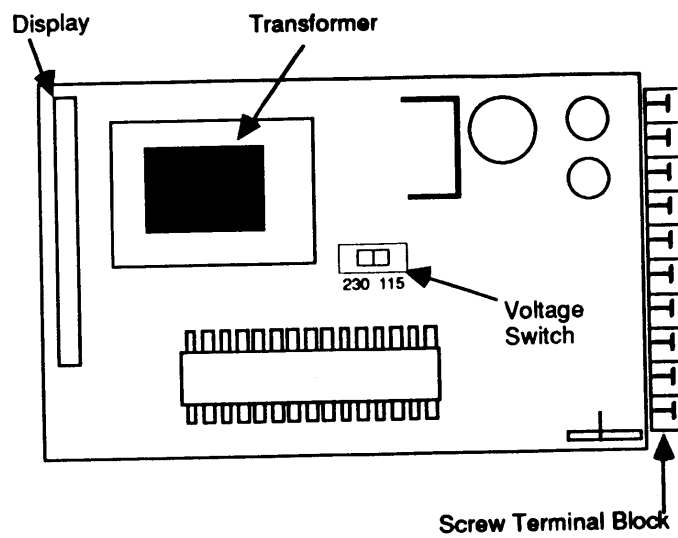

**fig. 11 -- Top View of Main board on display.;**

**Warning:** Dangerous voltages are exposed at the screw terminals. Always remove power before working in this area for rewiring, disassembly, and all other activities that involve proximity to electrical circuitry.

## The Internal Back Plane

The back plane of the series 8000 rack system is typically hand wired at the factory. Channels configured as blanks are normally left unconfigured because it is not always specified as to what will be in a slot in the future. In designing the series 8000 modules some standards have been adhered to accommodate expansion. The diagram in figure 12 details physical pin locations for the standard Eurocard connector. Table 2 gives the electrical standards used for designing compatible modules. Figure 15 is a template used for special wiring to the back plane. See the section on **Adding Additional Modules** for information concerning expansion. *When connecting other 3rd party equipment to the Series 8000 you must take care to avoid drawing too much power from the supply and/or adding additional noise to the output from the system (especially with digital cards such as A/D, D/A, or CPU).*

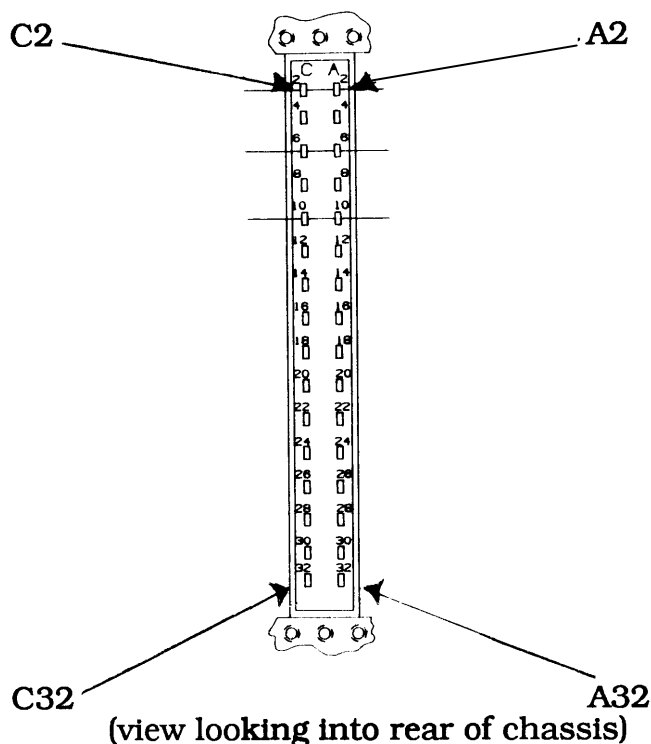

fig. 12 -- Physical Eurocard Pin Locations;

**Caution:** Be careful when connecting power, incorrect connections may damage your system.

function	Pin C	Pin A	function
+15VDCin	2	2	+15VDCin
SPL	4	4	SPL
-15VDCin	6	6	-15VDCin
SPL	8	8	SPL
Gnd	10	10	Gnd
I/O	12	12	I/O
I/O	14	14	I/O
I/O	16	16	I/O
I/O	18	18	I/O
I/O	20	20	I/O
I/O	22	22	I/O
Aux	24	24	Aux
Gnd	26	26	Gnd
I/O	28	28	I/O
Gnd	30	30	Gnd
I/O	32	32	I/O

**Table 2 -- Electrical Standards for Pinout;**

Pins labeled I/O are either input/output, pins labeled Gnd are always ground, pins labeled Aux are generally reset type functions, pins labeled SPL are not normally used but may be depending on the density required for pinout, the power supply input pins are obvious and the function cards are always set up to allow a +/-15 volt input.



## Internal Back Plane Connectors

The bare chassis eurocard connector is available for expansion and is part number 826020-002 for function cards. For most Kaman measuring systems use the SMA connector for coaxial connection, two part numbers are available: 853503-001 for single coil systems or 853503-002 for dual coil or differential systems. These connectors are prewired to the eurocard connector with bulkhead SMA's.

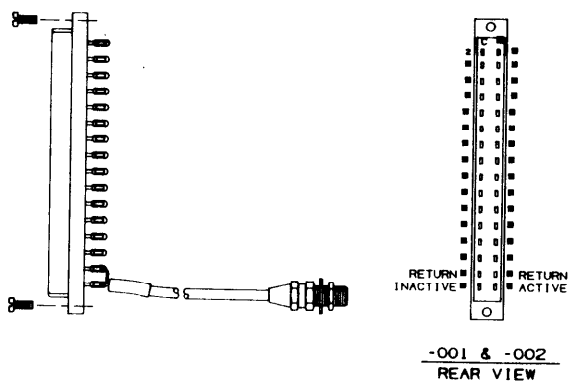

fig. 13 -- Single Coil Coaxial;

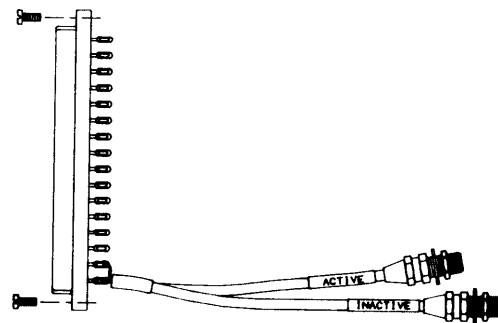

fig. 14 -- Dual Coil Coaxial;

## Adding Additional Modules

To add additional modules you will need to wire in additional Eurocard connectors to the back panel. You must have a soldering iron and 24AWG bus wire as well as insulated wire to connect any outputs that are required to the display or the back panel.

**Warning:** The integral power supply in racks utilize **high voltage** (120 or 240VAC). Unplug the unit before servicing.

- 1) Using the back plane template provided in fig. 15 map out the wiring of the unit. Power and ground connections from the power supply are shown in the diagram. Measuring channel and function cards I/O is shown in tables at the top of the template. You should refer to the specific manual on the module you are adding for further pinout information. The measuring channel sensor SMA pigtail connectors will already be attached to the Eurocard connector.
- 2) Determine the connector required:  
*If you are adding a measuring channel:*  
 you will need to have the 853503-001 or 853503-002 (depending on whether the measuring channel has one or two coils) connector with the coaxial bulkhead SMA connector (which comes with a measuring channel).  
*If you are adding a function card:*  
 you will need to have the 826020-002 Eurocard connector which comes with a function card.
- 3) Insure that the power cord is removed from the unit
- 4) Remove the back panel  
*On subracks:*  
 you should only remove two screws and carefully flip the panel up to avoid breaking any wires already connected.  
*On instrumentation cases:*  
 you should remove the top panel and the back panel being careful not to put any excess strain on connections already made.
- 5) Install the connector spaced the same number of holes as the rest of the connectors in the unit (there should be 6 empty holes between connectors). The 2 M2.5x6 screws (supplied -- Kaman PN 826028-146) should be used to secure the connector firmly in place. If you are installing a measuring channel and have an SMA pigtail it is best to wait until later to secure the SMA to the back panel.

- 6) Install the guide rails. Be sure to space as other guide rails in the unit are spaced (there should be 5 empty holes between guide rails). The guide rails snap into place in the upper and lower horizontal parts of the rack.
- 7) Solder in the power and ground connections. You will need to use 24AWG bus wire to connect the power and ground of any Kaman supplied module. The back plane template (fig. 15) shows the power and ground connections.
- 8) Solder in connections with insulated bus wire to the display and/or back panel as required for the application. The wiring template in fig. 15 gives the basic pinout for measuring channels and function cards. For third party modules you will have to refer to the specific information provided by the manufacturer. Typical connections are from the measuring channel out+ (C14/A14) and out- (A16/C16) to the display module (see the section on **Input Wiring to the Display**) or to an available pin on the back panel terminal block. If you are wiring in a function card you will need to use the measuring channel outputs as inputs to the function card. Typical function cards have inputs located on A12/C12 for channel 1 input and A16/C16 for channel 2 input. The location of the outputs vary depending on the type of output required.
- 9) Once you have carefully checked the wiring of outputs and inputs connect the SMA to the back panel and carefully reassemble the unit.



## The Back Panel

The exact back panel configuration will depend on the specific enclosure, measuring channels, and function cards to build a system. Figures 3, 5, and 7 show the back panel configurations for the 3 standard rack mounted enclosure types. Exact terminal block outputs depend on the measuring channel/function module configuration of the specific rack. See the section on **Back Panel I/O and Labeling** for specific information on terminal block outputs.

## Back Panel Power Input

The back panel has a universal IEC AC power input jack with on/off switch. The units can be configured for either 120VAC or 240VAC use (Note: If you switch power input to the unit and you have a display you *must* also switch the display power input as it is powered directly off the AC input -- failure to do so will damage the unit). See the section on **Input Voltage Selection** for switching the AC input. The power switch for the unit is located on the power entry module.

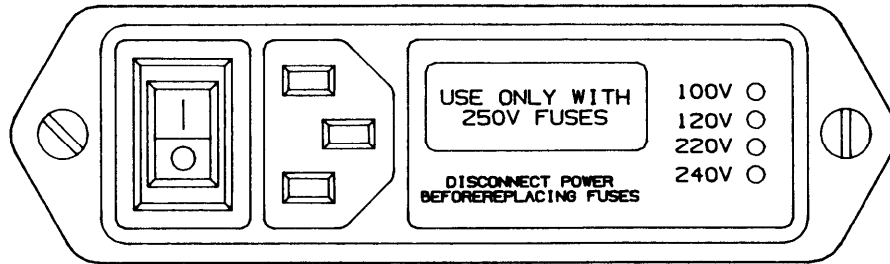

fig. 16 -- Power Entry Module

## Back Panel I/O and Labeling

Each back panel has terminal blocks used for I/O with special laser markings depending on the cards installed in the rack. The half rack has one 12 position terminal block, the 3/4 and full racks have two 12 position terminal blocks. The outputs are labeled to be consistent with the table below where 'x' refers to the channel number. Unfortunately, because of the density of the outputs on the back plane vs. the available outputs on the terminal blocks all outputs will not always be available on the terminal block. If you need a specific output not provided on the back panel terminal block please call the factory for information. If you have a function card not listed here please refer to the manual for the specific function card on terminal block labeling information.

Module	label	Function
8200	CHx	Signal out of measuring channel
GND		Ground from measuring channel
8200HT	CHx	Signal out of measuring channel
GND		Ground from measuring channel
VC8000	+Ix	Hi side current out of measuring channel
-Ix		Lo side current out of measuring channel
SP8000	SHx	Hi set point OC output for CHx
SLx		Lo set point OC output for CHx
CEx		common emitter output for CHx setpoints
GHx		Go set point high for CHx
GLx		Go set point low for CHx
SC8000	x+/-x	Summed Output
SHx		Hi set point output for CHx
SLx		Lo set point output for CHx
CEx		common emitter output for CHx
DY8000	PPX	Peak-to-Peak or Positive peak for CHx
NPX		Negative Peak for CHx
RMx		RMS for CHx
SHx		Hi set point output for CHx
SLx		Lo set point output for CHx
CEx		common emitter output for CHx
Any	GND	Ground
+V		+15 volt from internal supply or +15V input
-V		-15 volt from internal supply or -15V input

**Table 3 -- Terminal Block Labeling;**

## Back Panel Sensor Inputs

The back panels are configured with holes for panel mounted SMA connectors for coaxial sensor inputs. Depending on the number and type of measuring channels some of the holes may be plugged. The two rows of sensor inputs are marked A (or 'Active') and B (or 'Inactive')(for dual coil or differential sensor configurations) with a number between the A/B sensor inputs corresponding to the particular measuring channel input. For example, when installing the unit the sensor marked 'A' or 'Active' designated for channel 2 should be mated with the SMA connector on the back panel in row A, column 2. If the sensor is a single coil sensor, row B will be plugged. Figures 3, 5, and 7 show the back panel configurations for the 3 standard rack mounted enclosure types. If additional measuring channels are added in the field you must use coaxial cables on the sensor inputs.

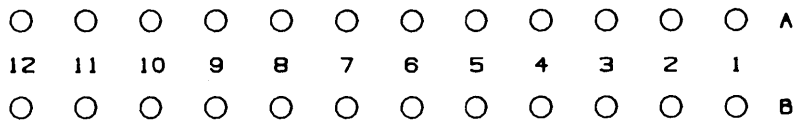

**fig. 17 -- Back Panel Sensor Inputs;**

## The Front Panels

The *series* 8000 enclosure front panels are essentially self configuring depending on the mix of function card and measuring channels. You will need to refer to the manual on the specific module for information on the front panel controls. See appendix A and B for some brief information on measuring channels and function cards. Since the MCD-8000 is essentially an integral part of the chassis, information on its operation and calibration is included in this manual.

## Module Side Panel Labeling

The modules are normally labeled on the side panel with special information concerning the module such as part number, sensor type, and whether the module is a master or a slave. With the measuring systems it is important to know whether the unit is a master or slave as the chassis are configured such that the master is the leftmost measuring channel slot and all other measuring channel slots ( on measuring channels with the same oscillator frequency) are configured as slaves. On function cards the dash number on the part number may be significant as to how the card was configured.

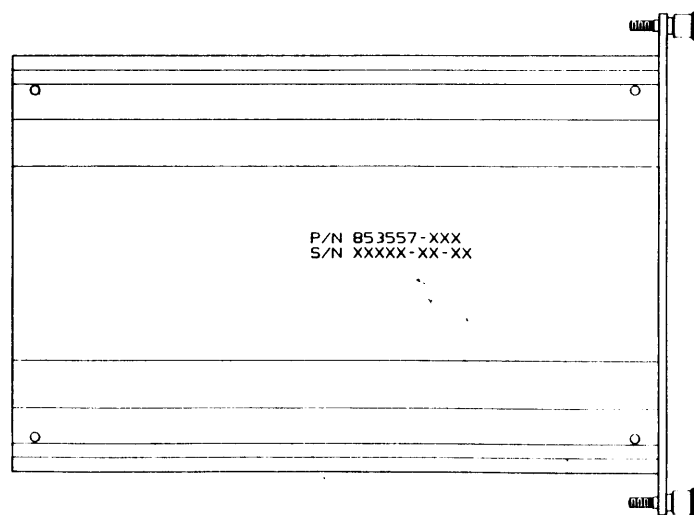

**fig. 18 -- Typical Module Side Panel Labeling;**



## MCD-8000 and 1/8 DIN Panel Mounted Displays

The MCD 8000 is a scalable 4 digit display module designed for accurate, reliable, measurement of voltage or milliamps from up to 6 inputs. The panel cutout for the MCD-8000 is a standard 1/8 DIN size. This allows flexibility in choosing an appropriate meter for a particular application. For most applications the MCD-8000 with its multi-channel scalable input is adequate. Information on the MCD-8000 is included in this manual. If another meter is used please refer to the specific manual on it for usage information. See Appendix C for specifications on the MCD-8000. 1/8 DIN panel cutouts are available in either single or dual configurations. For the single configuration use PN 814873-001 and for the dual configuration use PN 814873-002.

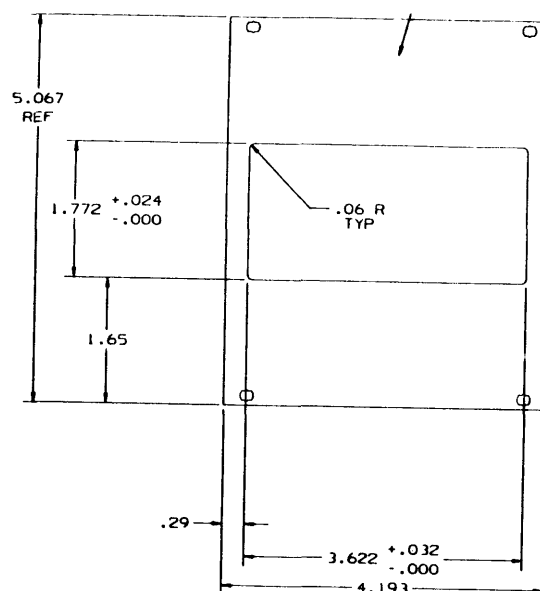

fig. 19 -- Single 1/8 DIN Mounting Panel 814873-001;

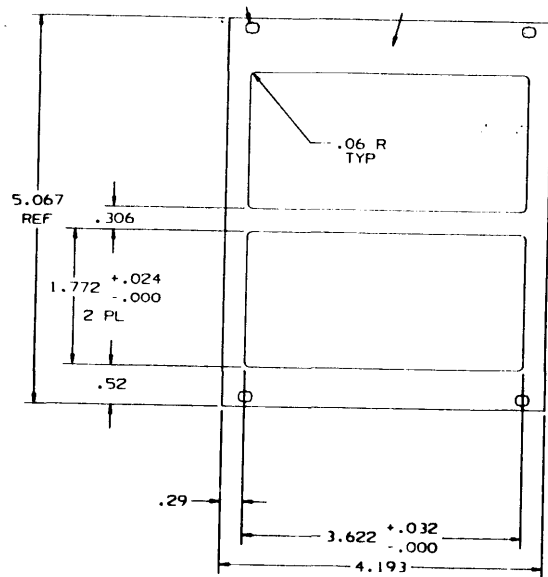
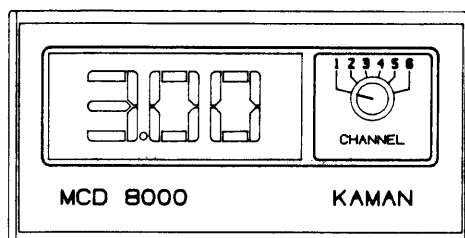

fig. 20 -- Dual 1/8 DIN Mounting Panel 814873-002;

## Using the Multi-Inputs

Select the input you wish to display by turning the front panel selector switch. The knob's index mark indicates the selected input as labeled on the front panel lens.



**fig. 21 -- MCD 8000 Front Panel;**

The display is normally configured to display the measuring channel output in the numbered position starting to the right of the display. For example, if you wish to read the output from channel 4 you will need to set the display switch to '4' which will read the output from the module 4 positions to the right of the display. *Some function card modules contain dual channel outputs, these modules will count as 2 positions.* For example, if you had 2 measuring channels, a dual RMS->DC converter card (dynamic module -004), and a third measuring channel in the fourth slot, when the display switch is on channel 4 you will read the RMS output of channel 2 and if the switch is on channel 5 you will read the measuring channel in the fourth position to the right of the display. *Some modules have no outputs that go to the display, these modules count as 0 positions.* The following table gives the displayed outputs and count. The channel numbers are relative to the modules to the left of the function card.

Module	Dash number	Displayed Outputs	1st Position	2nd
8200	any	1	----	----
8200HT	any	1	----	----
VC8000	any	0	----	----
SP8000	any	0	----	----
SC8000	any	1	Summed Output	----
DY8000	-001	2	Ch 1 P-P	Ch 1 RMS
DY8000	-002	2	Ch 1 +Peak	Ch 2 +Peak
DY8000	-003	2	Ch 1 -Peak	Ch 2 -Peak
DY8000	-004	2	Ch 1 RMS	Ch 2 RMS

**Table 4 -- Displayed Outputs;**

### Input wiring to the Display

The display can come in several configurations depending on the rack requirements. The basic connectors to the back of the module are from the measuring channels to the terminal block as shown in fig. 22 with the measuring channel output wired to the (+) terminal and the GND wired to the (-) terminal for a particular channel. If you have a bipolar meter please request drawing 853727 for information on special wiring.

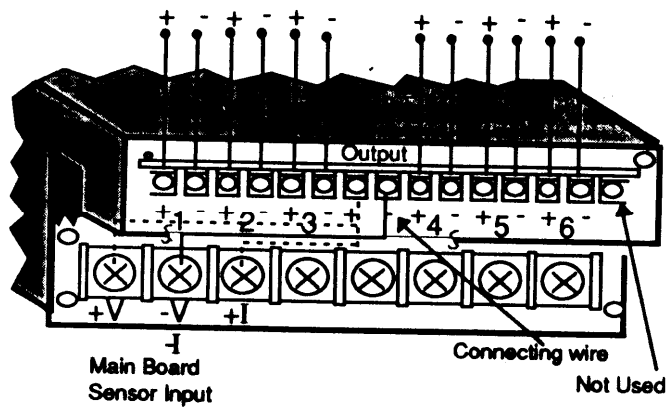

fig. 22 -- MCD 8000 Input Wiring;

**Warning:** Insure that the voltage label on the meter matches the power source input. Failure to have the display configured the same as the power input can result in destruction of the unit.

Connect the input sensor and power wires to the screw terminals at the back of the meter as shown below:

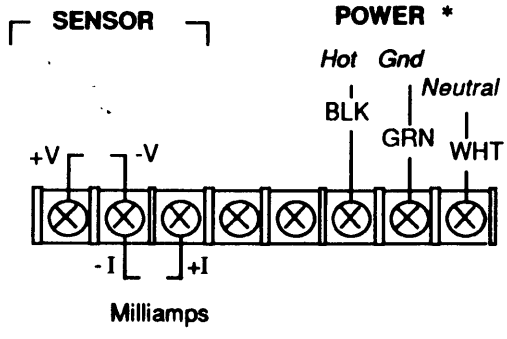

fig. 23 -- MCD 8000 Power Wiring;

## **0-10VDC Display Input Configuration**

The 0-10VDC input is by far the most common display configuration. It has differential inputs to the meter. It has a maximum resolution of 200 microvolts per count.

## **+/-5VDC Display Input Configuration**

The +/-5VDC input option is used where a high resolution bipolar input is required. It has a maximum resolution of 200 microvolts per count with the inputs configured single ended. This option requires the input conditioning board (Kaman PN 853737-002) to be wired to the display. This display is limited to a display reading of +/-9.99 (999x2 counts) since the first digit location is taken up by the sign.

## **+/-10VDC Display Input Configuration**

The +/-10VDC input option is used where a bipolar input with a large voltage swing is required. It has a maximum resolution of 400 microvolts per count with the inputs configured single ended. This option requires the input conditioning board (Kaman PN 853737-001) to be wired to the display. This display is limited to a display reading of +/-9.99 (999x2 counts) since the first digit location is taken up by the sign.

## 4-20mA Display Input Configuration

The MCD 8000 can take either voltage or current inputs. When configuring for current input you need to snap off the front panel lens to gain access to the display board. Behind the display is a DIP switch used to set the indicators input measuring mode. You will also need to change the wiring on the display terminal block (see section on Input Wiring to the Display) to go into the +I and -I terminals. *This mode is not normally used but may be if there is a special request to display the output from the VC8000 or other third party module that has 0-20mA or 4-20mA output.* When configured for current input all channels will be configured to measure current.

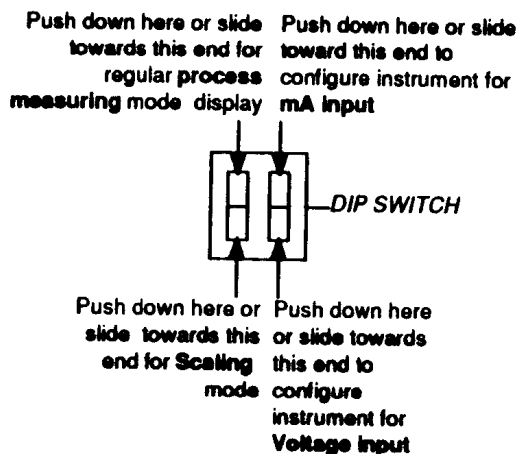

fig. 24 -- Voltage/Current Input Dip Switch;

When using the current loop type inputs, it may be desirable to install diodes on each channel to maintain loop continuity of disengaged channels. Use 1N4002 DIODES installed in the terminal block screw terminals or soldered onto the multi-channel input circuit board (you must take the display apart to do this, pads are provided on the board).

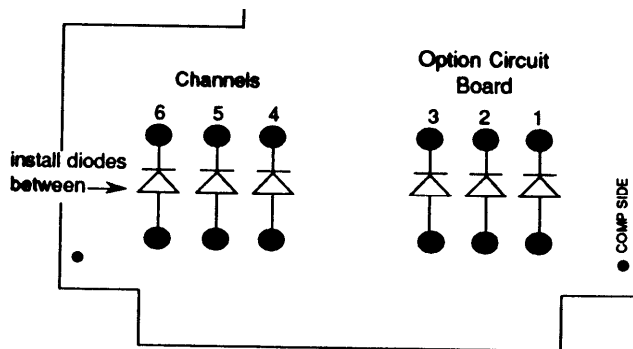

fig. 25 -- Diodes For Loop Continuity in Current Mode;

## Calibration

The MCD-8000 calibration consists of a 2 point calibration that adjusts the offset and slope of the resulting display. The scale factor of the MCD-8000 can be adjusted for a minimum of 200 microvolts per count (400 microvolts per count with +/-10VDC input option). In order to calibrate the unit the following steps should be followed:

- 1) Select the input channel with the maximum voltage range to calibrate from. The selector switch only changes the input. Once calibrated to a particular input the remaining 5 channels will have the same calibration (you cannot have a different calibration for each separate input). You must have the ability to change the input to the meter so that you have the 2 data points near the extreme ends of the input range.
- 2) Determine the display values for the 2 data points. You must insure that the display has a minimum of 200 microvolts per count (400 microvolts per count with +/-10VDC input option) or you will get an error when you try to calibrate. To determine number of counts available for display divide the maximum voltage input by 10000 (2000 for bipolar inputs). The decimal point location is inconsequential for determining the display counts. Keep in mind that the meter has four digits and ignore the decimal point location when determining the number of counts. For example if you have a 0-.4 VDC sensor output you can display  $.4\text{VDC}/.0002=2000$  counts. If you are calibrating for English units and  $.4\text{VDC}=40$  mils and want to display the result in English units you would probably not want to display the result in inches because the maximum the display would show for the range would be  $.0040$  so you would be losing resolution. If you display the result in mils you may be tempted to try  $40.00$  but this won't work because it requires 4000 counts and you can only use 2000 counts. This means that the best compromise is display in mils because you can display  $40.0$  (losing the first digit this gives you 400 counts which is less than the 2000 count maximum). If you must have more display resolution you will need to increase the voltage output so that the minimum voltage/count requirement is met. Don't forget, if you have a bipolar option the first digit gets used by the sign so you only have +/-999 counts to work with.

- 3) Pull off the switch cap and pop off the front of the meter panel using a small flat head screwdriver and twisting slightly in the slot near the bottom center of the panel.

**Note:** The DIP switch may either be a rocker type (press down on appropriate end) or a slider type (slide toward appropriate end). The drawing in fig. 26 details the adjustment activities.

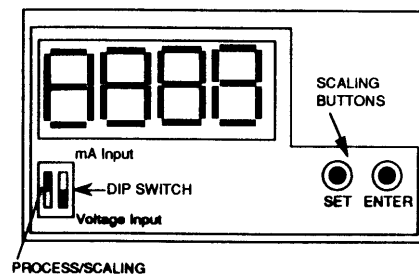

fig. 26 -- MCD 8000 Adjustment Switches;

- 4) Actual calibration occurs in the SCALING mode. Push down or slide towards the bottom the left most dip switch. This will put the unit in scaling mode and the word "LO" will appear on the display.

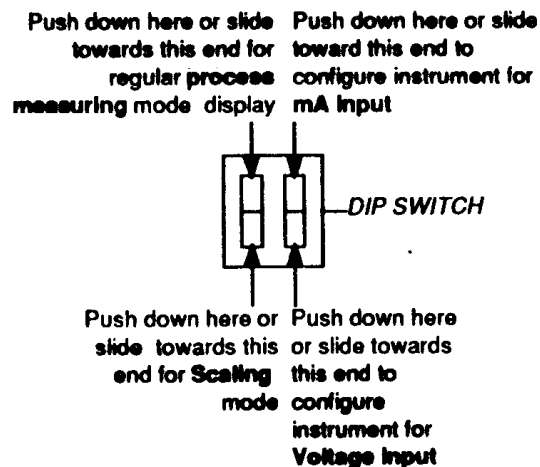

fig. 27 -- Process/Scaling Dip Switch;



- a** Position the sensor or simulated input so that it is near the low scale point (e.g. 0 mils, 0 Volts, 4 mA) push the "ENTER" button.
- b** Use the "SET" button to change the value of the flashing digit. When the flashing digit is correct, push the enter button. The flashing digit will now move to the next right hand digit. Continue until all digits are correct with the rightmost digit still flashing. (e.g. OOOO-- still flashing)
- c** Push both "SET" and "ENTER" buttons at the same time to program in this scale factor. In other words, when the indicator receives a process input signal identical to the simulated (calibration) one it will display the same value shown now. (e.g. 4mA = 0000).

**Note:** While the indicator is calibrating itself "oo" will appear in the display. After a few seconds it will return to display "HI" (go to step 4d) or "ERR" (see error message table).

- d** with "HI displayed change the input to simulate the +Full scale (High) (e.g. 20mA). Repeat steps as shown in steps **a**, **b**, and **c** changing the digits to represent the Full Scale desired display (e.g. 7500). When complete the indicator will then go to the decimal point position.

**5)** with the decimal points displayed

- a** push the "SET" button until desired position is displayed.
- b** Push "SET" and "ENTER" buttons at the same time to program into memory.

- 10)** Return the "PROCESS/SCALING" dip switch to the PROCESS position. Replace the front lens.

**Note:** Pushing both the "SET" and "ENTER" button at the same time always causes the indicator to recalibrate itself to the given input and what is on the display at that moment. As a protective measure, if scaling changes are made and not terminated this way no recalibration will occur, previous values will remain.

**Note:** As a further protective measure, the "SET" and "ENTER" buttons are not functional unless the PROCESS/SCALING switch is in the SCALING position.

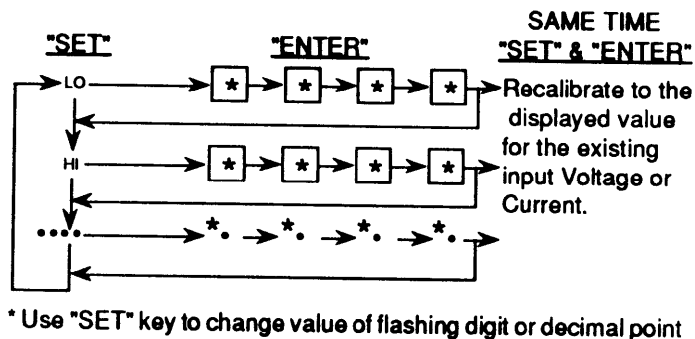

fig. 28 -- Button Function Legend;

MESSAGE DISPLAYED	DURING CALIBRATION/SCALING MODE		DURING NORMAL PROCESS MEASURING MODE	
	CAUSE	CURE	CAUSE	CURE
E11	Slope error. Same values entered for both "LO" and "HI"	"LO" and "HI" values Must be different. Push "set" button and re-enter for "LO" and "HI" values.	N/A	
E12	Slope error. Too many display counts for too little input voltage or current	Push "SET" button. Reduce the number of display counts for the given input. example: Reduce 700.0 to 700	N/A	
OL, OL	Overloaded input or display. Input exceeds specification	Check input voltage or current. Must be within 0-10VDC 0-20mA	Input exceeds maximum specification or display is beyond -999 or 9999	Check input voltage or current for over range or break/open circuit.
----	Internal A/D overload.	Turn power off, wait 25 seconds, and turn power on again. If problem persists, call repair department	Internal A/D overload	Turn power off, wait 25 seconds, and turn power on again. If problem persists, call repair department

Table 5 -- MCD-8000 Error Message Table;

### Appendix A -- Measuring Channel Configuration

The heart of the system is the measuring channel. Currently Kaman offers a wide variety of signal conditioning modules and inductive sensors. The table below is a brief description of ranges and display parameters for the standard line of sensors. Please refer to the KDM-8200 instruction manual for further information on calibration and usage of the inductive sensors.

SENSOR MODELS	MEASURING RANGE	TYPICAL OFFSET	ANALOG VOLTAGE	DISPLACEMENT FULL SCALE	
	Inch (mm)	Inch (mm)	Inch (mm)	SENSITIVITY mV/mil (mV/mm)	MCD-8000 English (Metric)
.5SU/.5U2	.020 (0.5)	.002 (0.05)	2.00 (0.5)	100 (1000)	20.00 (_500)
1U1/1U2	.040 (1.0)	.006 (0.13)	0.40 (1.0)	10 (1000)	_40.0 (1.000)
2S1	.080 (2.0)	.015 (0.38)	0.80 (2.0)	10 (1000)	_80.0 (2.000)
2UB1	.080 (2.0)	.015 (0.38)	0.80 (2.0)	10 (1000)	_80.0 (2.000)
2U2	.100 (2.5)	.025 (0.63)	1.00 (2.5)	10 (1000)	100.0 (2.500)
3U1	.120 (3.0)	.020 (0.51)	1.20 (3.0)	10 (1000)	120.0 (3.000)
4S1	.160 (4.0)	.020 (0.51)	1.60 (4.0)	10 (1000)	160.0 (4.000)
6U1/6U2	.240 (6.0)	.035 (0.89)	2.40 (0.6)	10 (100)	240.0 (_6.00)
15U1/15U2	.600 (15)	.150 (3.81)	0.60 (1.5)	1 (100)	_600. (15.00)
30U1/30U2	1.20 (30)	.300 (7.5)	1.20 (3.0)	1 (100)	1200. (30.00)
60U1	2.40 (60)	.600 (15)	2.40 (.60)	1 (10)	2400. (_60.0)
15N (diff)	+/- .009 (.25)	.006 (.15)	+/-9.0 (9.0)	1000 (36000)	+/-9.00. (+/- .250)
20N (diff)	+/- .009 (.25)	.006 (.15)	+/-9.0 (9.0)	1000 (36000)	+/-9.00. (+/- .250)
1925(HT)	.050 (1.27)	.005 (.127)	2.50 (2.5)	50 (2)	_50.0 (_1.27)
1925M(HT)	.040 (1.0)	.002 (.05)	2.00 (2.0)	50 (2)	_40.0 (_1.00)
1950(HT)	.150 (3.81)	.01 (.254)	1.50 (1.50)	10 (400)	100.0 (_3.81)
1950M(HT)	.100 (2.54)	.005 (.127)	1.00 (1.00)	10 (400)	100.0 (_2.54)
1975(HT)	.200 (5.00)	.010 (.254)	2.00 (2.00)	10 (400)	200.0 (_5.00)
1975M(HT)	.100 (2.54)	.005 (.127)	1.00 (1.00)	10 (400)	100.0 (_2.54)

Note: "\_xx.x" indicates that the left most meter display character (for higher resolution) is not available at the scale factor selected due to limitations of the meter. The meter has a minimum input requirement of 200 microvolts per count with a 10V total range except in bipolar +/-10V input systems where the minimum input requirement is 400 microvolts per count.

Table 6 -- Series 8000 Sensor Family;

## Basic Measuring Channel Configuration

Most of the displacement measuring channels offered by Kaman have the same pinout and front panel configuration. They utilize inductive bridge technology which has a high sensitivity and is generally insensitive to contaminants such as dust, dirt, and oil. If adding additional measuring channels to an existing unit you will need to be careful to wire the 'Sync out' pin from a master modules to the 'Sync in' pin on all other module which must be configured as slaves to avoid beat note interference problems. Please see a Kaman 8200 user manual (PN 860059), 8200 differential supplement (PN 860067), or 8200 High Temp manual (PN 860064) for more specific information on the particular sensor system that you have.

### Back Plane Pin Configuration

function	Pin C	Pin A	function
+15VDCin	2	2	+15VDCin
N/C	4	4	N/C
-15VDCin	6	6	-15VDCin
N/C	8	8	N/C
Gnd	10	10	Gnd
N/C	12	12	N/C
Out+	14	14	Out+
Out-	16	16	Out-
N/C	18	18	N/C
N/C	20	20	N/C
N/C	22	22	N/C
Aux	24	24	Aux
Gnd	26	26	Gnd
Sync out	28	28	Sync in
Gnd	30	30	Gnd
Sen B	32	32	Sen A

fig. 29 -- Basic Measuring Channel

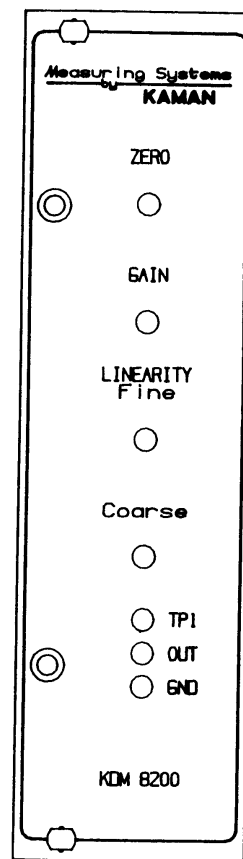

## Appendix B -- Function Card Configuration

Any *series* 8000 enclosure can be configured with optional function cards. Function cards available include Voltage to Current conversion (for 4-20mA outputs), dual set points, summation/comparator (for thickness applications), dynamic measurement (RMS->DC conversion or Peak measurements), and a prototyping card. Each function card will have its own manual describing pinouts and usage. Please refer to the appropriate function card manual for specific questions.

**Caution:** *Be careful when connecting power, incorrect connections may damage your system.*

The following pages briefly describe some of the function cards available along with the pinout for reference.

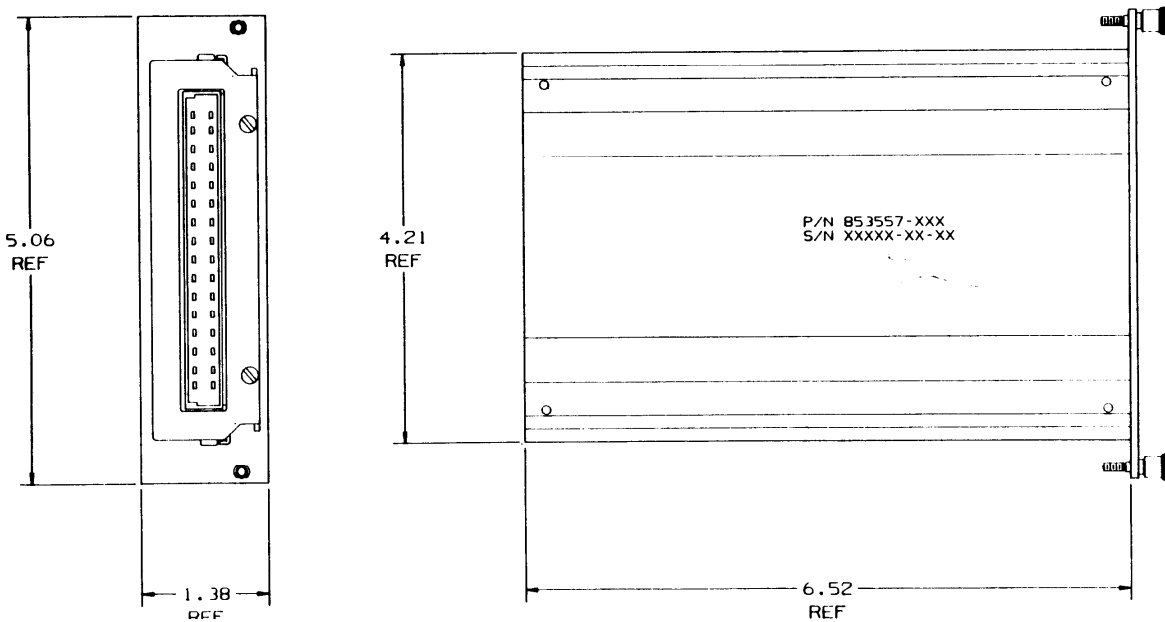

**fig. 30 -- Module Reference Dimensions;**

Note: All dimensions are  
in inches

## VC8000 Voltage to Current Converter Configuration

The VC8000 was designed to convert a 0-5 volt DC input to either a 0-20mA or 4-20mA output. The isolated loop supply and current output make it ideal for noisy industrial environments. Please see the VC8000 user manual (PN 860061) for more specific information.

### Back Plane Pin Configuration

function	Pin C	Pin A	function
+15VDCin	2	2	+15VDCin
N/C	4	4	N/C
-15VDCin	6	6	-15VDCin
N/C	8	8	N/C
Gnd	10	10	Gnd
Vin1	12	12	Vin1
Gnd	14	14	Gnd
Vin2	16	16	Vin2
Gnd	18	18	Gnd
Outlo1	20	22	Outhi1
Outlo2	22	22	Outhi2
+Vloop	24	24	+Vloop
Gnd	26	26	Gnd
Sync	28	28	Sync
Gnd	30	30	Gnd
N/C	32	32	N/C

fig. 31 -- VC8000 Voltage to Current Converter

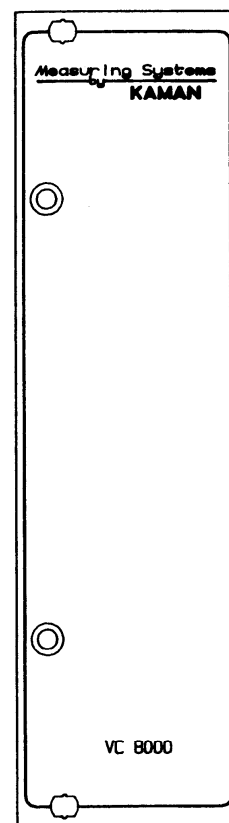

## SC8000 Summation/Comparator Configuration

The SC8000 Summation/Comparator module was designed for use when a direct reading of ID, OD, or thickness was desirable. The module performs an analog summation on the inputs and has an integral window comparator for monitoring out of tolerance conditions. Please see the SC8000 user manual (PN 860062) for more specific information.

### Back Plane Pin Configuration

function	Pin C	Pin A	function
+15VDCin	2	2	+15VDCin
N/C	4	4	N/C
-15VDCin	6	6	-15VDCin
N/C	8	8	N/C
Gnd	10	10	Gnd
Vin1	12	12	Vin1
Gnd	14	14	Gnd
Vin2	16	16	Vin2
Gnd	18	18	Gnd
CE	20	20	HI Setpoint
CE	22	22	LO Setpoint
AUX	24	24	AUX
Gnd	26	26	Gnd
SUM OUT	28	28	SUM OUT
Gnd	30	30	Gnd
REM C	32	32	REM C

fig. 32 -- SC8000 Summation/Comparator

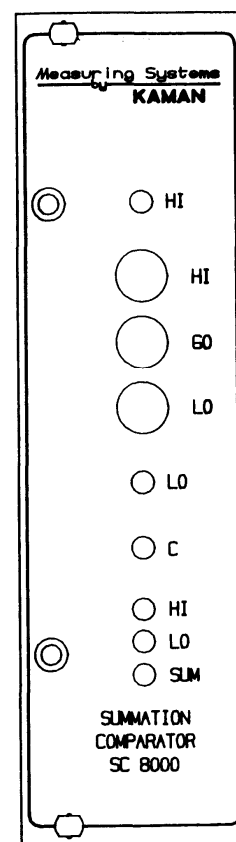

## DY8000 Dynamic Module Configuration

The DY8000 Dynamic Module was designed to take dynamic inputs such as shaft runout, vibration or ultrasonic weldhorn amplitude and convert them to a DC voltage easily readable and quantifiable on the display module. The DY8000 can perform either single peak-to-peak, dual positive peak, dual negative peak, or dual RMS measurements. Integral progressive comparators allow for easy monitoring of out of tolerance conditions. Please see the DY8000 user manual (PN 860048) for more specific information.

### Back Plane Pin Configuration

function	Pin C	Pin A	function
+15VDCin	2	2	+15VDCin
Gnd	4	4	SPI
-15VDCin	6	6	-15VDCin
Gnd	8	8	HLD
Gnd	10	10	Gnd
Vin1	12	12	Vin1
Gnd	14	14	Gnd
Vin2	16	16	Vin2
Sp2 Adj	18	18	SP1 Adj
OutloSP1	20	20	OuthiSP1
OutloSP2	22	22	OuthiSP2
Reset	24	24	Reset
Gnd	26	26	Gnd
Out1	28	28	Out1
Gnd	30	30	Gnd
Out2	32	32	Out2

fig. 33 -- DY8000 Dynamic Module

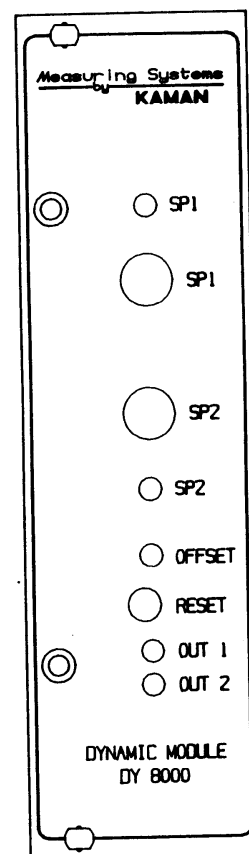



## SP8000 Dual Set Point Configuration

The Dual Set Point module was designed with two separate channels of either window or progressive comparator operation. The configuration allows for alarm and shutdown with Hi, Lo, or Go outputs. Please see the SP8000 user manual (PN 860090) for more specific information.

### Back Plane Pin Configuration

function	Pin C	Pin A	function
+15VDCin	2	2	+15VDCin
SPALA	4	4	SPAHA
-15VDCin	6	6	-15VDCin
SPALB	8	8	SPAHB
Gnd	10	10	Gnd
Vin1	12	12	Vin1
Gnd	14	14	Gnd
Vin2	16	16	Vin2
CEB	18	18	CEA
OuthiB	20	20	OuthiA
OutloB	22	22	OutloA
SPI*	24	24	Reset
Gnd	26	26	Gnd
CH1GL	28	28	CH1GH
Gnd	30	30	Gnd
CH2GL	32	32	CH2GH

fig. 34 -- SP8000 Dual Set Point

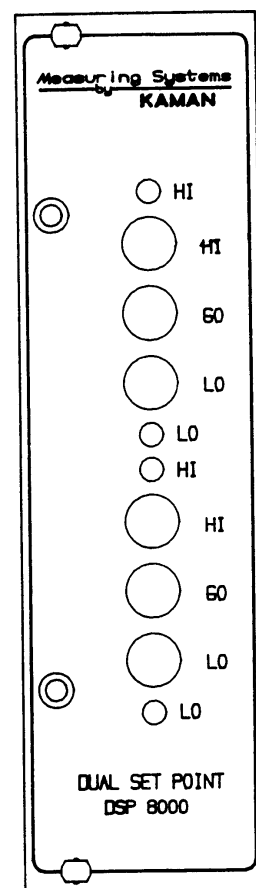

## Appendix C -- MCD-8000 Display Specifications

### MCD 8000 Functional Specifications

*Input Range:* 0-10VDC or 0-20mA

Note: Kaman Special input module (PN 853727) allows either a +/-5VDC or +/-10VDC input to the meter but changes it to be a single ended input.

*Sensitivity:* 200 microvolts/count or 0.4microamps per count

Note: on units with the Kaman input module (PN 853727) with a +/-10VDC input, the display will only have 400 microvolt per count sensitivity.

*Input Impedance:* Voltage mode  $\geq 1$  Megohm  
Current mode 5 ohms

Note: on units with the Kaman input module (PN 853727) with a +/-10VDC input, the display will have a 20k ohm input impedance.

*A/D read rate:* 2 per second nominal

*Power:* 115VAC +/-10%, 50-60 Hz; 230 VAC +/-10%, 50-60Hz  
switch selectable

## **MCD 8000 Performance Specifications**

### *Reference Operating Conditions (ROC):*

+/-10% line voltage  
 23+/-2°C ambient temperature  
 <80% RH non-condensing

*Accuracy (at ROC):* 0.02% of reading +/- 1 count

### *Noise Rejection:*

NMRR: >-60dB @ 50/60Hz, +/- .1Hz  
 CMRR: >-120dB @ 50/60Hz, +/- .1Hz with 250 ohm unbalanced

### *Overload Protection:*

Power lead to ground: 1500VDC or ACRMS  
 Across inputs: Voltage up to 250VDC or VAC for 1 min., +V to -V  
 Current up to 150mADC or mAAC for 1 min., +I to -I

*Stability with Temperature:* Zero 1uV/°C, Span 0.01% reading/°C

*Stability with Time:* 10 counts per year maximum

*Repeatability:* +/- 1 count

## **MCD 8000 Environmental/Physical Specifications**

### *Operating Range:*

Temperature: 5 to 45°C  
 Relative Humidity: 10-80% RH non-condensing

*Storage Range:* -40 to 65°C

### *Power:*

115VAC +/-10%, 50-60 Hz  
 230VAC +/-10%, 50-60 Hz

## Appendix D -- Replacement or Expansion Parts

### Rack Parts:

<u>PN</u>	<u>Description</u>
814873-001	Single meter 1/8 DIN 21T Wide Front Panel
814873-002	Dual meter 1/8 DIN 21T Wide Front Panel
853737-001	MCD-8000 1/8 DIN Replacement Meter (1-6 label)
853737-002	MCD-8000 1/8 DIN Replacement Meter (7-12 label)
822238-C001	Power Cord 110V
814639-001	Single Slot Blank Front Panel
814639-002	Dual Slot Blank Front Panel
826029-001	Thumbscrews (4 per panel required)
853503-001	Rack Side Euroconnector with single SMA connector
853503-002	Rack Side Euroconnector with dual SMA connectors
826020-002	Euroconnector for function cards
826019-001	Guide Rails (2 per slot required)
850643-004	Accessory Kit with Feeler Gauge
850643-005	Accessory Kit without Feeler Gauge
820222-001	Hole Plugs (for unused sensor inputs)
853727-001	Bipolar Meter Conversion Kit

### Function Card Modules:

<u>PN</u>	<u>Description</u>
853557-001	SC8000 Summation/Comparator Module (C-(A+B) operation)
853558-001	VC8000 Single Voltage to Current Module (4-20mA output)
853558-002	VC8000 Dual Voltage to Current Module (4-20mA output)
853717-001	SP8000 Dual Set Point Module
853669-001	DY8000 Dynamic Module Single Channel PP/RMS
853669-002	DY8000 Dynamic Module Dual Channel Positive Peak
853669-003	DY8000 Dynamic Module Dual Channel Negative Peak
853669-004	DY8000 Dynamic Module Dual Channel RMS

<p><b>Note:</b> There is a wide variety of measuring channels please see a Kaman Sales Brochure for replacement measuring channels. Be sure to specify if unit is to be a master or a slave module.</p>
---

### Series 8000 Sensor Family

SENSOR SCALE MODELS 8000	MEASURING	TYPICAL	ANALOG	DISPLACEMENT	FULL
	RANGE	OFFSET	VOLTAGE	SENSITIVITY	MCD-
	Inch (mm) English (Metric)	Inch (mm)	Inch (mm)	mV/mil (mV/mm)	
.5SU/.5U2	.020 (0.5)	.002 (0.05)	2.00 (0.5)	100 (1000)	20.00 (.500)
1U1/1U2	.040 (1.0)	.006 (0.13)	0.40 (1.0)	10 (1000)	_40.0 (1.000)
2S1	.080 (2.0)	.015 (0.38)	0.80 (2.0)	10 (1000)	_80.0 (2.000)
2UB1	.080 (2.0)	.015 (0.38)	0.80 (2.0)	10 (1000)	_80.0 (2.000)
2U2	.100 (2.5)	.025 (0.63)	1.00 (2.5)	10 (1000)	100.0 (2.500)
3U1	.120 (3.0)	.020 (0.51)	1.20 (3.0)	10 (1000)	120.0 (3.000)
4S1	.160 (4.0)	.020 (0.51)	1.60 (4.0)	10 (1000)	160.0 (4.000)
6U1/6U2 (.600)	.240 (6.0)	.035 (0.89)	2.40 (0.6)	10 (100)	240.0
15U1/15U2 (15.00)	.600 (15)	.150 (3.81)	0.60 (1.5)	1 (100)	_600.
30U1/30U2 (30.00)	1.20 (30)	.300 (7.5)	1.20 (3.0)	1 (100)	1200.
60U1 (.60.0)	2.40 (60)	.600 (15)	2.40 (.60)	1 (10)	2400.
15N (diff) 9.00. (+/- .250)	+/- .009 (.25)	.006 (.15)	+/-9.0 (9.0)	1000 (36000)	+/-
20N (diff) 9.00. (+/- .250)	+/- .009 (.25)	.006 (.15)	+/-9.0 (9.0)	1000 (36000)	+/-
1925(HT) (.1.27)	.050 (1.27)	.005 (.127)	2.50 (2.5)	50 (2)	_50.0
1925M(HT) (.1.00)	.040 (1.0)	.002 (.05)	2.00 (2.0)	50 (2)	_40.0
1950(HT) (.3.81)	.150 (3.81)	.01 (.254)	1.50 (1.50)	10 (400)	100.0
1950M(HT) (.2.54)	.100 (2.54)	.005 (.127)	1.00 (1.00)	10 (400)	100.0
1975(HT) (.5.00)	.200 (5.00)	.010 (.254)	2.00 (2.00)	10 (400)	200.0
1975M(HT) (.2.54)	.100 (2.54)	.005 (.127)	1.00 (1.00)	10 (400)	100.0

Note: "\_xx.x" indicates that the left most meter display character (for higher resolution) is not available at the scale factor selected due to limitations of the meter. The meter has a minimum input requirement of 200 microvolts per count with a 10V total range except in bipolar +/-10V input systems where the minimum input requirement is 400 microvolts per count.

## Appendix E -- Warranty and Repair

# **Kaman Instrumentation Operations Products Standard Limited Warranty**

Products of Kaman Instrumentation are warranted to be free from defects in materials and workmanship when installed and operated in accord with instructions outlined in the instruction manual.

Kaman Instrumentation's obligation under this warranty shall be limited to repair or replacement (at the discretion of Kaman Instrumentation) of the defective goods returned to Kaman's plant within one (1) year from date of shipment. Extreme environment sensors are limited to the maximum operating temperature as specified within the most current Kaman Measuring Systems Extreme Environment Systems data sheets.

This warranty is valid except when the products have been subject to misuse, accident, negligent damage in transit or handling, or operation outside the conditions prescribed in the data sheet or instruction manual. This will be determined by Kaman Instrumentation personnel.

In no event shall Kaman be liable for incidental or consequential damages, including commercial loss, resulting from any article sold under this Agreement.

In the event Buyer fails to limit to Kaman's warranty set forth above, any express or implied warranty Buyer may make with respect to any product of which any article sold thereunder is a component, Buyer shall indemnify and hold Kaman harmless from any and all liability, costs and expenses to which Kaman may be subjected as a result of Buyer's failure to so limit its express or implied warranties.

THIS WARRANTY IS EXCLUSIVE AND IS MADE IN LIEU OF ALL OTHER WARRANTIES; AND THOSE IMPLIED WARRANTIES, INCLUDING SPECIFICALLY THE WARRANTIES OR MERCHANTABILITY AND FITNESS FOR A PARTICULAR PURPOSE ARE HEREBY EXPRESSLY LIMITED TO ONE (1) YEAR DURATION. NO MODIFICATION OR ALTERATION OF THE FOREGOING WARRANTY AND LIMITATION OR REMEDIES PROVISIONS SHALL BE VALID OR ENFORCEABLE UNLESS SET FORTH IN A WRITTEN AGREEMENT SIGNED BY KAMAN AND THE BUYER.

Kaman Instrumentation Warranty No. 7A

## **Customer Service Information**

Should you have any questions regarding this product, please contact an applications engineer at **Kaman Measuring Systems 800-552-6267**. You may also contact us through our web site at: [www.kamansensors.com](http://www.kamansensors.com).

## **Service/Repair Information**

In the event of a malfunction, please call for return authorization:

Customer Service/Repair **Kaman Measuring Systems:**

**860-632-4442**